

## Rotation Sensor Challenge

***Suggested Time***

60 minutes

***Age***

15 - 18

***Challenge***

Construct a rotation sensor with the highest degree of accuracy and repeatability.

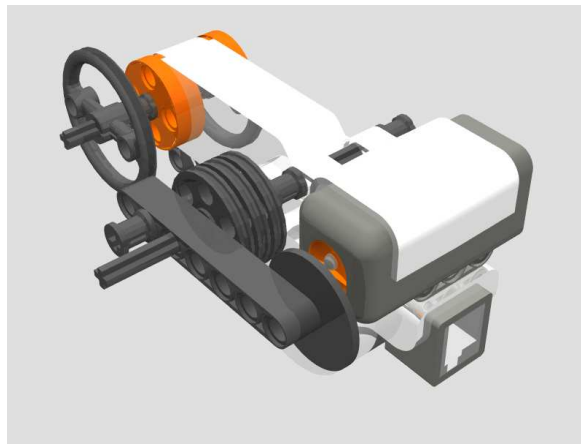
***Topics***

Gears, Sensors, Data Analysis, Limits of Technology

***Subjects***

Engineering &amp; Technology

***Materials***

- NXT
- Motor
- Light Sensor
- Assortment of LEGO Technic pieces

***Building Instructions***

1. Build a rotation sensor using a motor and a light sensor.

***Hints:***

*Make sure to build a plate at the end of the rotating motor. This will allow the light sensor to register a dark event.*

*The light sensor will not be able to register a dark event if the plate is too far away from it.*

**Programming Instructions**

1. Using ROBO LAB Inventor, program the motor to operate and the light sensor to log data.

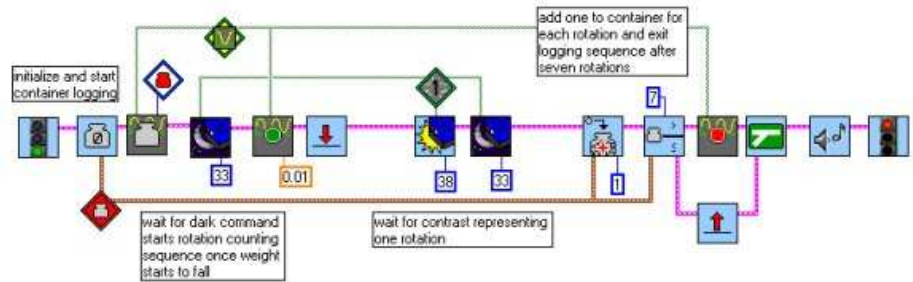

**In Action**

This rotation sensor counts the number of times the motor completes a full turn. This number is displayed on the NXT screen. After 8 turns, the motor stops.